

HARDWARE FITTINGS



SOCKET CLEVIS FOR ARCING HORN

BRITISH STANDARD (BS)

Part Number	Drawing Number	Ref Code	Min. Breaking Strength (kN)	A (mm)	B (mm)	C (mm)	F Ball (mm)	Bolt Size (mm)
920642-000	DK95002/02	15/31A	70	130	86	18.5	16B	Ø16
Y37777-000	DK95102/02	28/31A	125	122	71	21.5	20	Ø20
244680-000	DK95202/02	42/31A	190	159	76	25	24	Ø22

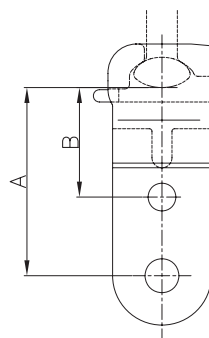
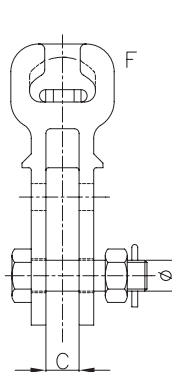
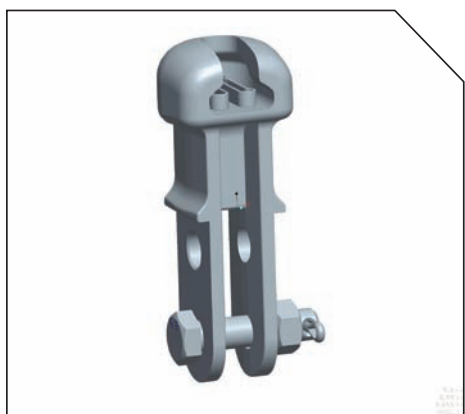

Material: Galvanized Steel

BRITISH & INTERNATIONAL STANDARD (BS & IEC)

Part Number	Drawing Number	Ball Type	Min. Breaking Strength (kN)	A (mm)	B (mm)	C (mm)	D (mm)
004908-000	A4DD09796T	16mm W Clip	120	20	35	59	Ø16

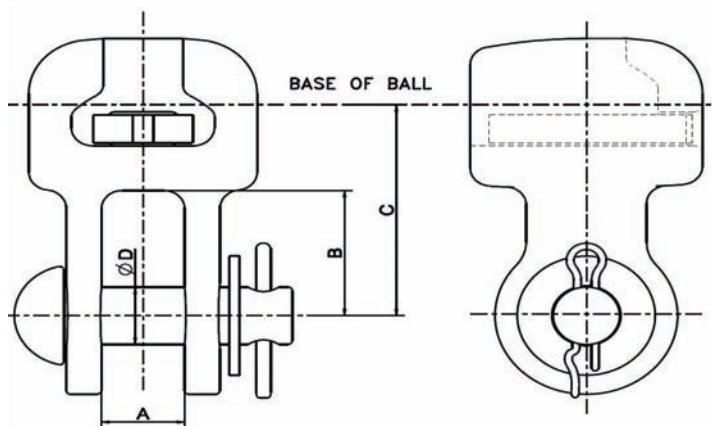
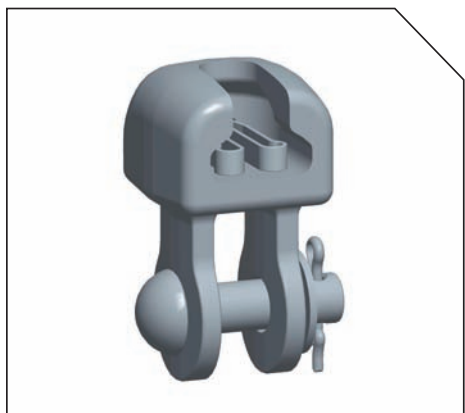

Material: Galvanized Forged Steel

HARDWARE FITTINGS



SOCKET CLEVIS

AUSTRALIAN STANDARD (AS)

Part Number	Drawing Number	Ref Code	Min. Breaking Strength (kN)	B (mm)	S (mm)	E (mm)	F Ball (mm)	Bolt Size (mm)
185094-000	SC70A	PLP-SC70A	70	18.5-21.5	56-62	26.5-29.5	16	Ø16
824308-000	SC70AR	PLP-SC70AR	70	18.5-21.5	56-62	26.5-29.5	16	Ø16
F00666-000	SC120A	PLP-SC120A	120	18.5-21.5	56-62	26.5-29.5	16	Ø16
648706-000	SC120AR	PLP-SC120AR	120	18.5-21.5	56-62	26.5-29.5	16	Ø16
380280-000	SC160A	PLP-SC160A	160	22.5-25.5	59-65	33.3-36.8	20	Ø20
CB4513-000	SC160AR	PLP-SC160AR	160	22.5-25.5	59-65	33.3-36.8	20	Ø20

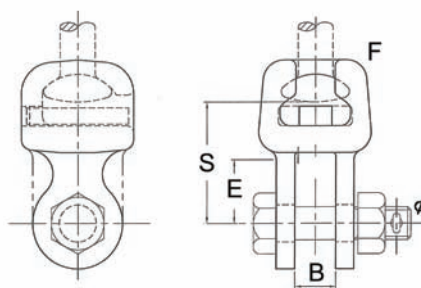

Material: Galvanized Forged Steel

BRITISH STANDARD (BS)

Part Number	Drawing Number	Ref Code	Min. Breaking Strength (kN)	A (mm)	B (mm)	C (mm)	F Ball (mm)	Bolt Size (mm)
A13103-000	DK95104/02	28/37A	125	76	41	19	20	Ø20
469030-000	DK95204/02	42/37A	190	76	43	21.5	24	Ø22
986256-000	DK95210/02	42/104A	190	105	64	28.5	24	Ø30

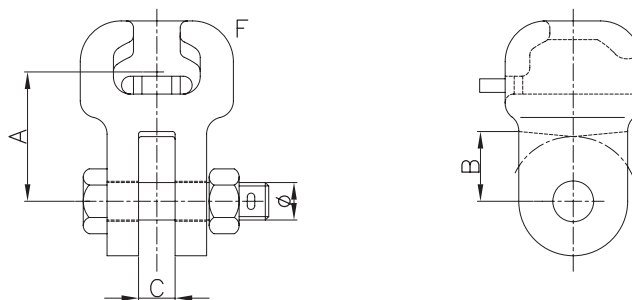
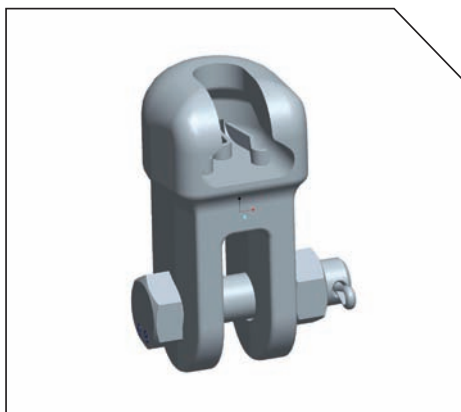

Material: Galvanized Steel

HARDWARE FITTINGS



SOCKET CLEVIS (CONT.)

AMERICAN STANDARD (ANSI)

Part Number	Drawing Number	Ball Type	Min. Breaking Strength (kN)	A (mm)	B (mm)	C (mm)	D (mm)
600562-000	A4DD14016T	Socket 52-3 Type B (A-Clip)	120	21	42	65	Ø16

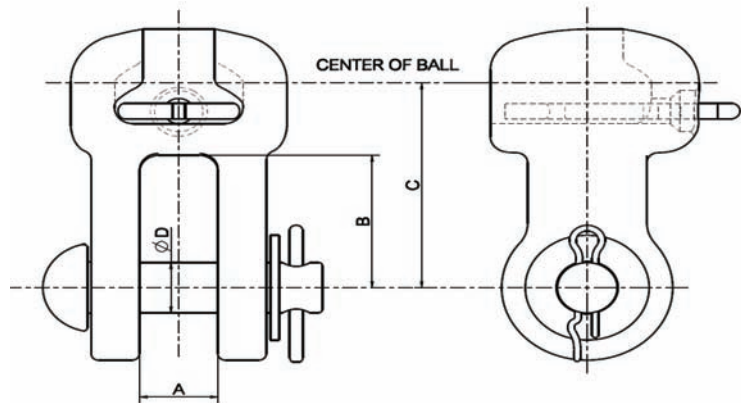
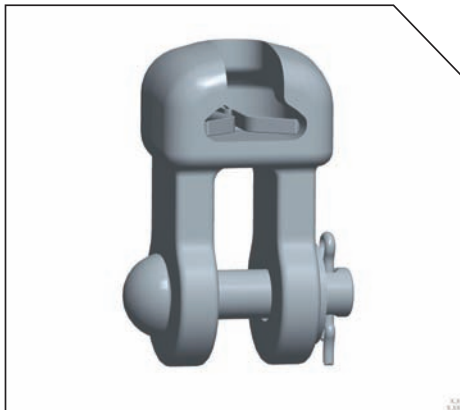

Material: Galvanized Ductile Iron

INTERNATIONAL STANDARD (IEC-16A)

Part Number	Drawing Number	Ball Type	Min. Breaking Strength (kN)	A (mm)	B (mm)	C (mm)	D Bolt Size (mm)
926096-000	A4DD3802T	16mm R-CLIP	120	21	42	65	Ø16

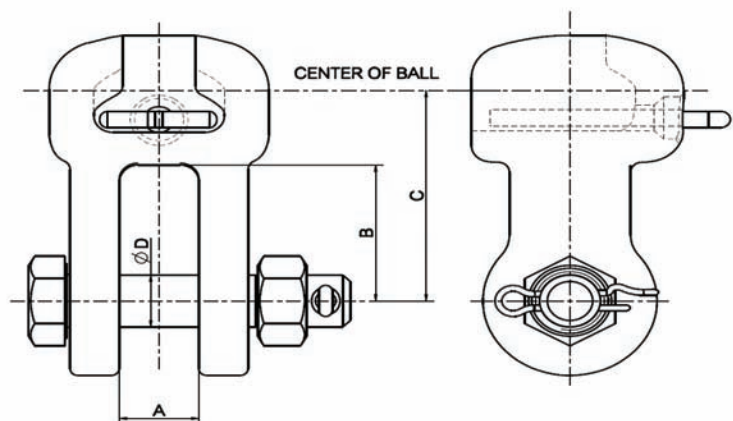
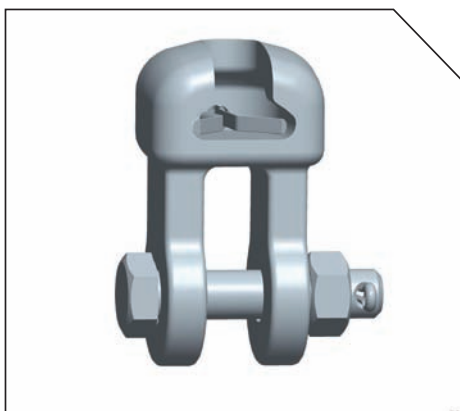

Material: Galvanized Ductile Iron

HARDWARE FITTINGS



SOCKET CLEVIS (CONT.)

AMERICAN STANDARD (ANSI)

Part Number	Drawing Number	Ball Type	Min. Breaking Strength (kN)	A (mm)	B (mm)	C (mm)	D (mm)
871638-000	A4DD09371T	Socket 52-5 Type J (R-Clip)	137	24	33	54	Ø19
F10091-000	A4DD07536T*	Socket 52-5 Type J (R-Clip)	140	24	33	54	Ø20

* Assembly with Bolt Type

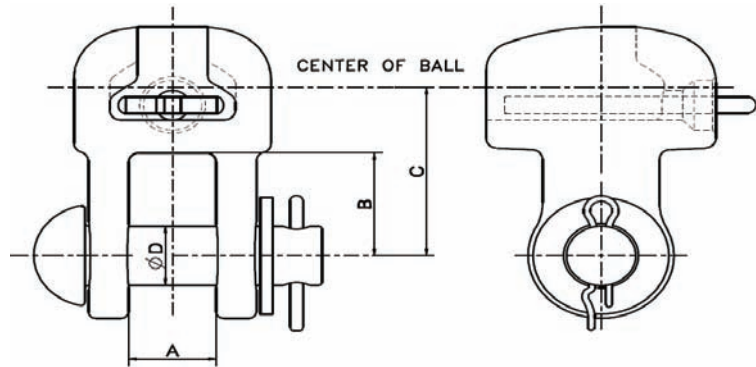
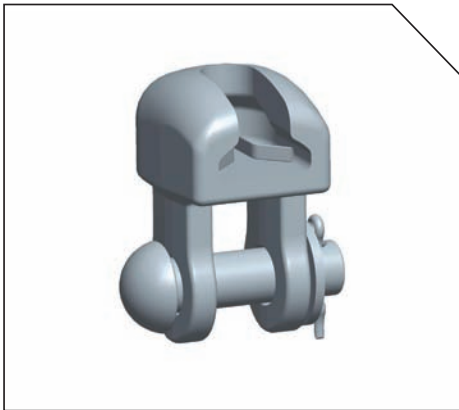

Material: Galvanized Forged Steel

BRITISH STANDARD (BS)

Part Number	Drawing Number	Ball Type	Min. Breaking Strength (kN)	A (mm)	B (mm)	C (mm)	D (mm)
D63525-000	A4DD14417T	20mm W - Clip	160	26	40	67	Ø19
D72268-000	A4DD14168T*	20mm W - Clip	160	26	40	67	Ø20

* Assembly with Bolt Type

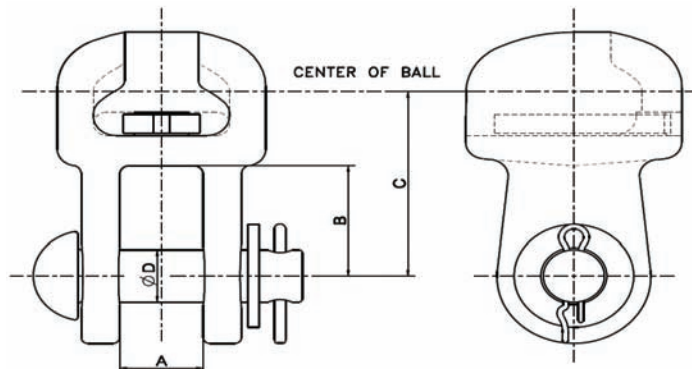
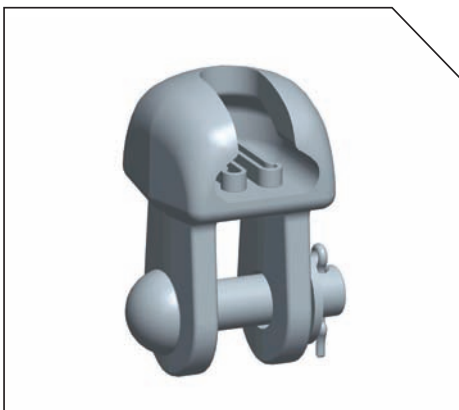

Material: Galvanized Forged Steel

HARDWARE FITTINGS



SOCKET CLEVIS (CONT.)

BRITISH STANDARD (BS)

Part Number	Drawing Number	Ball Type	Min. Breaking Strength (kN)	A (mm)	B (mm)	C (mm)	D Bolt Size (mm)
060468-000	A4DD08714T	20mm R - Clip	225	24	42	70	Ø20

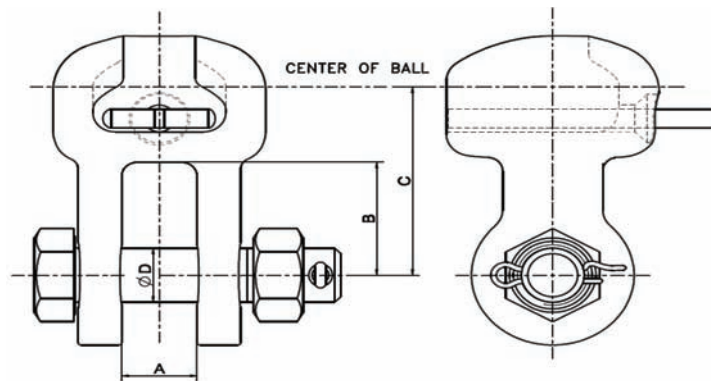
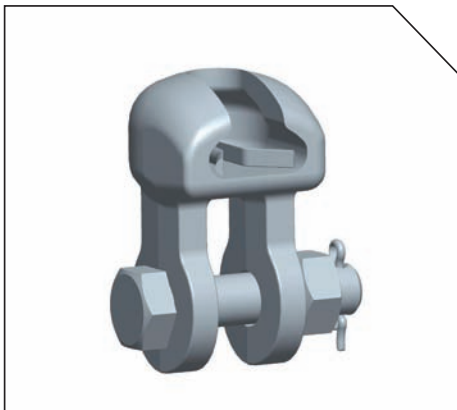

Material: Galvanized Forged Steel

AMERICAN STANDARD (ANSI)

Part Number	Drawing Number	Ball Type	Min. Breaking Strength (kN)	A (mm)	B (mm)	C (mm)	D (mm)
494990-000	A4DD17712T	Socket 52-8, 52-11 - Type K (R-Clip)	222	25	63	90	Ø22

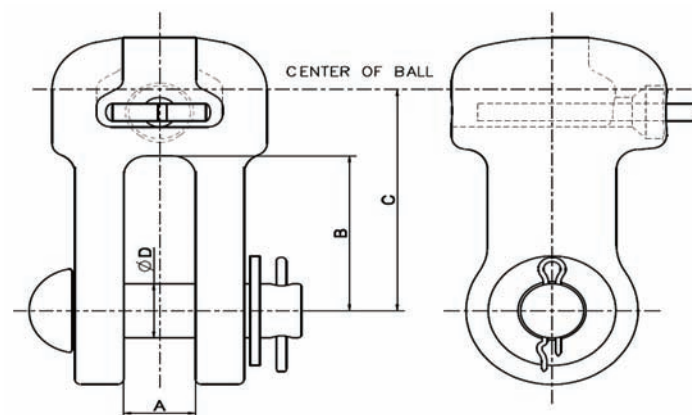
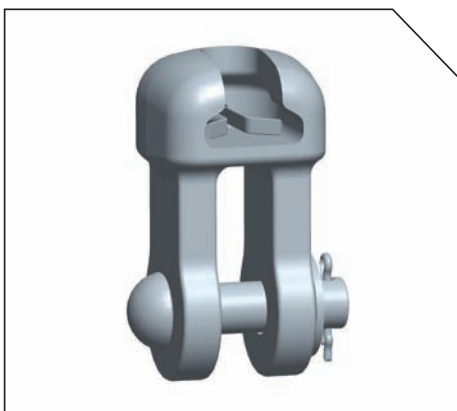

Material: Galvanized Ductile Iron

HARDWARE FITTINGS



SOCKET CLEVIS FOR ARCING HORN 67/31

BRITISH STANDARD (BS)

Part Number	Drawing Number	Ref Code	Min. Breaking Strength (kN)	A (mm)	B (mm)	C (mm)	F (Ball)	Bolt Size
481074-000	DK95304/02	67/31	300	150	76	28.5	24	Ø27

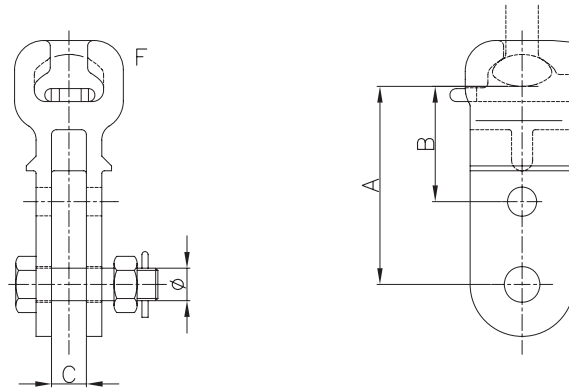
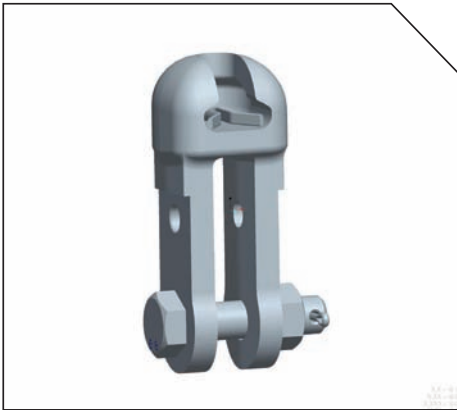

Material: Galvanized Steel

TWISTED SOCKET CLEVIS FOR ARCING HORN

BRITISH STANDARD (BS)

Part Number	Drawing Number	Ref Code	Min. Breaking Strength (kN)	A (mm)	B (mm)	C (mm)	F Ball (mm)	Bolt Size
A57469-000	DK95145/02	28/131A	125	150	71	28.5	20	Ø27

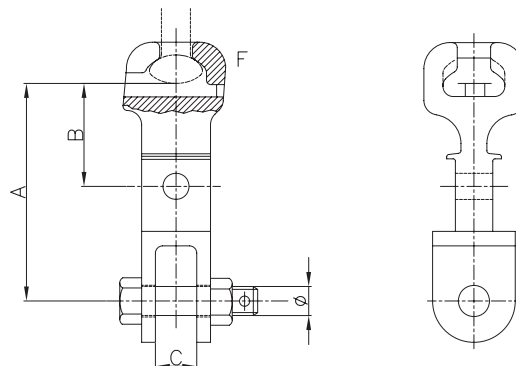
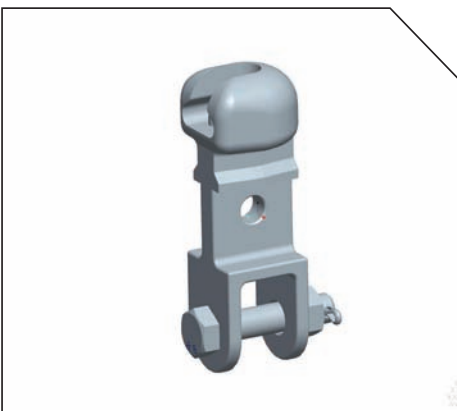

Material: Galvanized Steel

HARDWARE FITTINGS



SOCKET CLEVIS ADAPTOR FOR ARCING HORN

BRITISH STANDARD (BS)

Part Number	Drawing Number	Ref Code	Min. Breaking Strength (kN)	A (mm)	B (mm)	C (mm)	F Ball (mm)	Bolt Size
596512-000	DK95208/02	42/45	190	210	127	21.5	24	Ø22

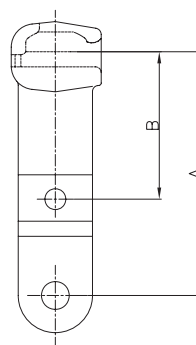
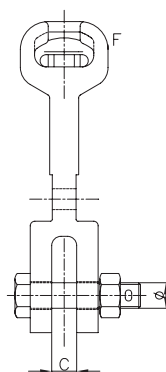
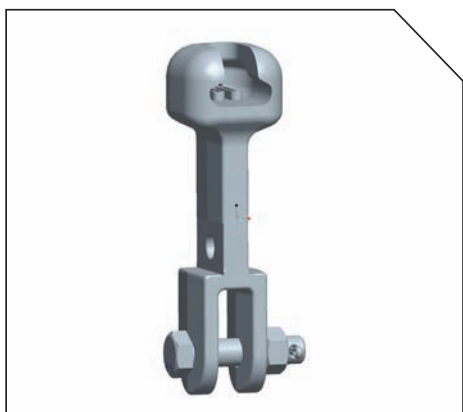

Material: Galvanized Steel

SOCKET EYE FOR ARCING HORN

BRITISH & INTERNATIONAL STANDARD (BS & IEC)

Part Number	Drawing Number	Ball Type	Min. Breaking Strength (kN)	A (mm)	B (mm)	C (mm)	D (mm)
194364-000	A4DD09797T	16mm (Type B) W - Clip	120	24	51	110	Ø18
339296-000	A4DD07899T	16mm (Type A) R - Clip	120	19	51	110	Ø18
F55842-000	A4DD09802T	16mm (Type B) W - Clip	120	16	51	110	Ø18

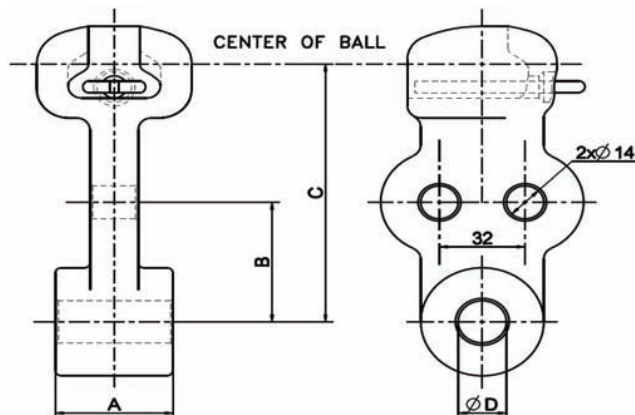
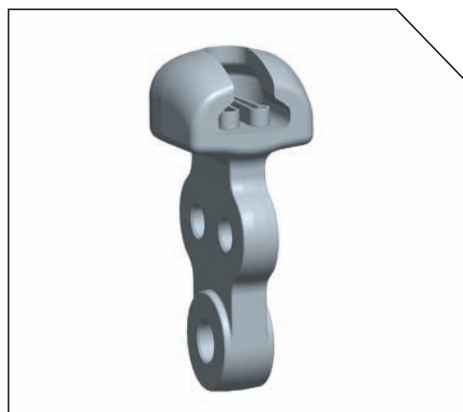

Material: Galvanized Forged Steel

HARDWARE FITTINGS



SOCKET EYE FOR ARCING HORN (CONT.)

INTERNATIONAL STANDARD (IEC)

Part Number	Drawing Number	Ball Type	Min. Breaking Strength (kN)	A (mm)	B (mm)	C (mm)	D (mm)
898806-000	A4DD11585T	16mm (Type A) R - Clip	120	44	51	110	Ø18
D82392-000	A4DD11702T	16mm (Type A) R - Clip	120	30	51	110	Ø18
E67311-000	A4DD12631T	16mm (Type A) R - Clip	80	16	51	110	Ø18

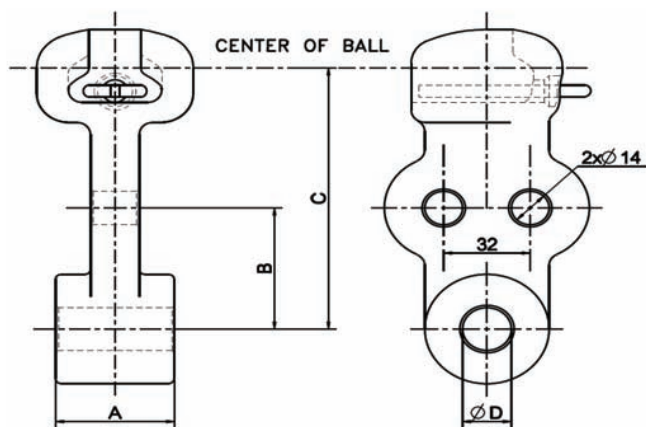
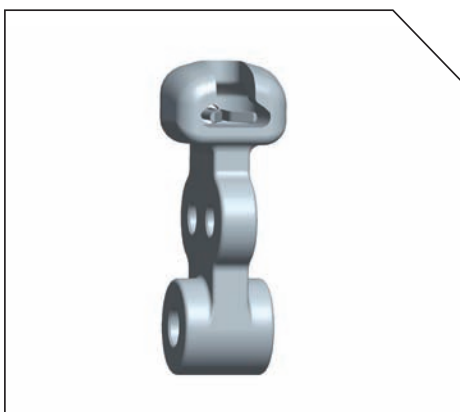

Material: Galvanized Ductile Iron

AMERICAN STANDARD (ANSI)

Part Number	Drawing Number	Ball Type	Min. Breaking Strength (kN)	A (mm)	B (mm)	C (mm)	D (mm)
D84115-000	A4DD11506T	Socket 52-3 (Type B) A - Clip	120	44	51	110	Ø18
518220-000	A4DD3083T	Socket 52-3 (Type B) A - Clip	120	30	51	110	Ø18
698268-000	A4DD07485T*	Socket 52-3 (Type B) A - Clip	120	22	51	110	Ø18
425226-000	A4DD16100T*	Socket 52-5 (Type J) R - Clip	137	19	51	110	Ø18

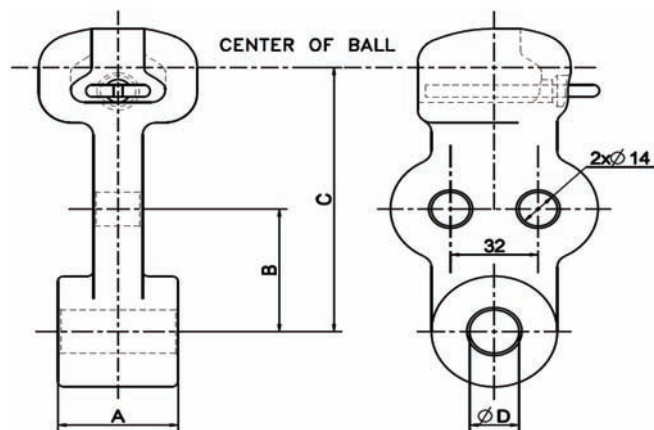
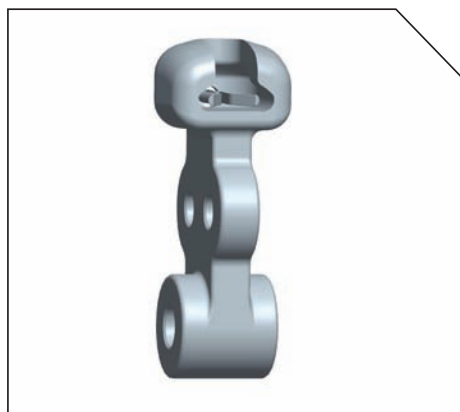

Material: Galvanized Ductile Iron
* Galvanized Forged Steel

HARDWARE FITTINGS



SOCKET EYE

AMERICAN STANDARD (ANSI)

Part Number	Drawing Number	Ball Type	Min. Breaking Strength (kN)	A (mm)	B (mm)	C (mm)
D03502-000	A4DD11763T	Socket 52-3(Type B) A Clip	120	44	64	Ø18
613408-000	A4DD1045T	Socket 52-3(Type B) A Clip	80	30	64	Ø18
E27414-000	A4DD07526T	Socket 52-5(Type J) A Clip	120	30	64	Ø18
701470-000	A4DD07840T	Socket 52-3(Type B) A Clip	110	26	60	Ø18
098788-000	A4DD08364T	Socket 52-3(Type B) A Clip	120	22	64	Ø18
956568-000	A4DD17834T	Socket 52-3 (Type B) A Clip	80	19	62	Ø22
800264-000	A4DD17835T	Socket 52-3 (Type B) A Clip	80	16	62	Ø18

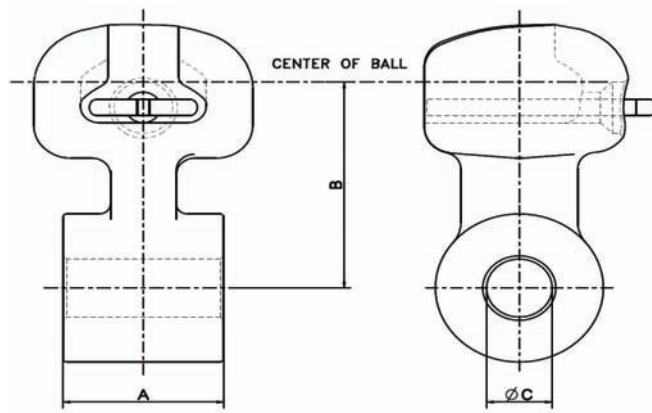
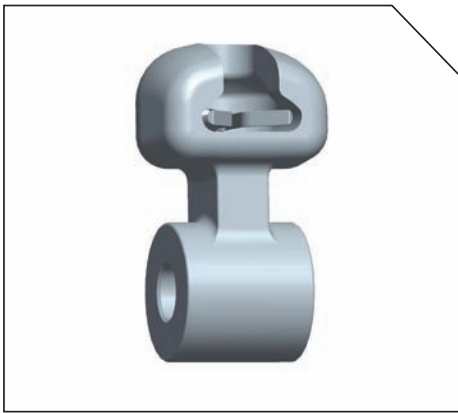

Material: Galvanized Ductile Iron

INTERNATIONAL STANDARD (IEC)

Part Number	Drawing Number	Ball Type	Min. Breaking Strength (kN)	A (mm)	B (mm)	C (mm)
E13136-000	A4DD10762T	16mm (Type 16A) R Clip	120	30	64	Ø18

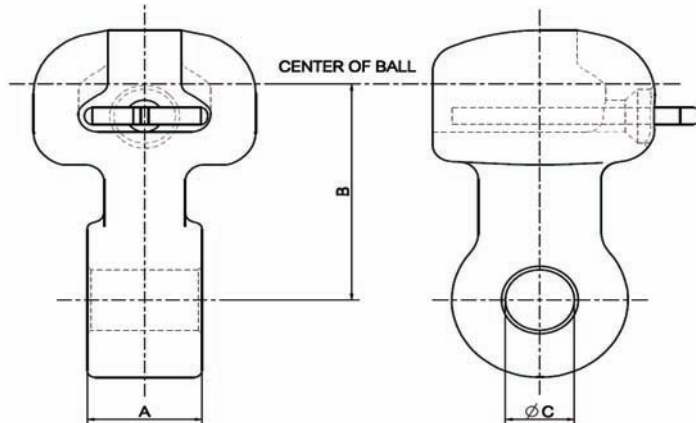
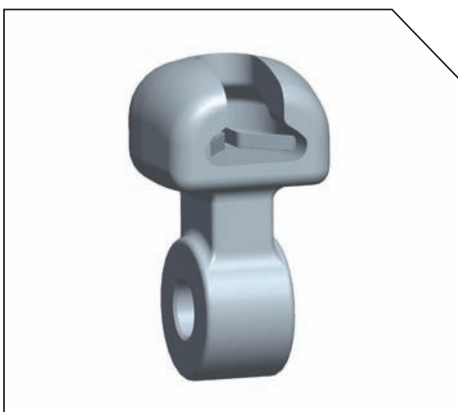

Material: Galvanized Ductile Iron

HARDWARE FITTINGS



SOCKET 'Y' CLEVIS

AMERICAN STANDARD (ANSI)

Part Number	Drawing Number	Ball Type	Min. Breaking Strength (kN)	A (mm)	B (mm)	C Bolt Size (mm)
369626-000	A3DD06459T	Socket 52-8 & 52-11 (Type K) - R Clip	227	53	83	Ø22

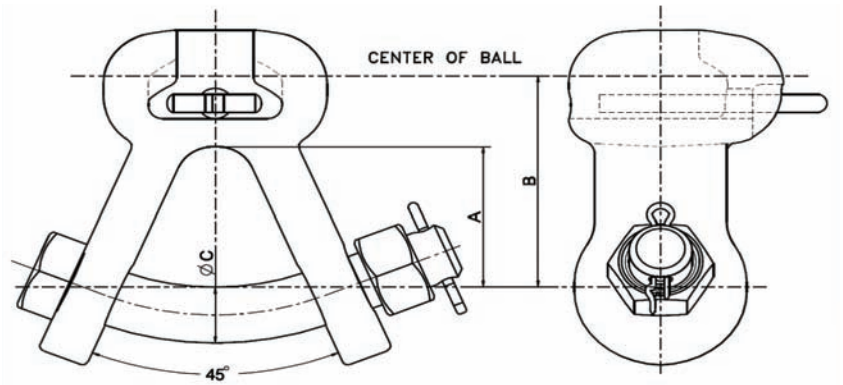
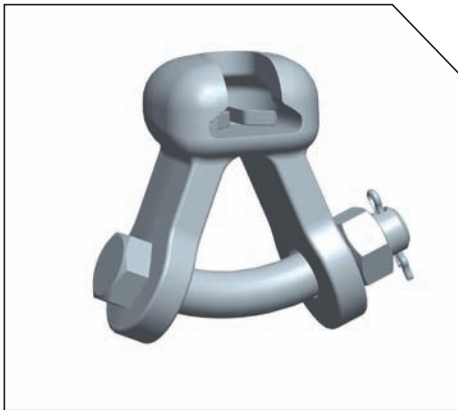

Material: Galvanized Forged Steel

SOCKET THIMBLE

AUSTRALIAN STANDARD (AS)

Part Number	Drawing Number	Ref Code	Min. Breaking Strength (kN)	A (mm)	B (mm)	C (mm)	S (Ball)	F Ball (mm)
398274-000	AU51930	PLP-STH70	70	32	29	50	70	16

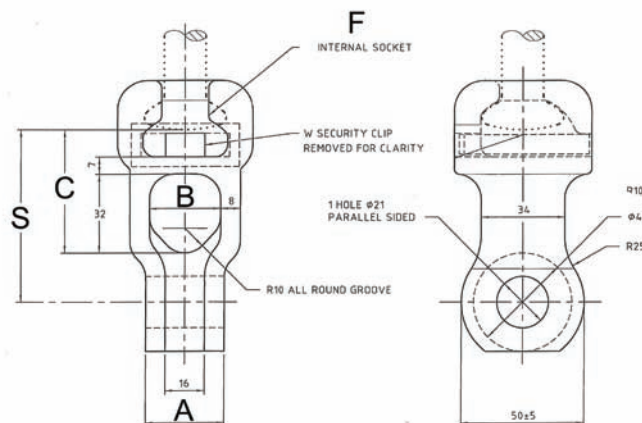

Material: Galvanized Steel

HARDWARE FITTINGS



SOCKET THIMBLE (CONT.)

BRITISH STANDARD (BS)

Part Number	Drawing Number	Ref Code	Min. Breaking Strength (kN)	A (mm)	B (mm)	C (mm)	E (mm)	F Ball (mm)
549718-000	STT6260001	STT6260001	70	30-32	40	20	23.5	16B

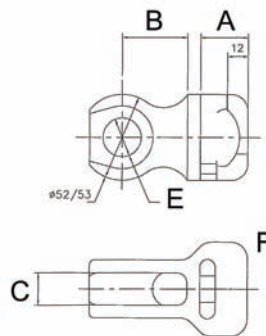

Material: Galvanized Steel

BRITISH STANDARD (BS)

Part Number	Drawing Number	Ref Code	Min. Breaking Strength (kN)	A (mm)	B (mm)	C (mm)	E (mm)	F Ball (mm)
953572-000	STT6260012W	STT6260012W	70	25	30	116	22	16B

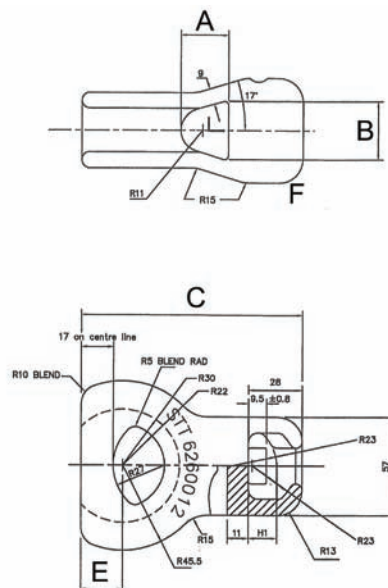

Material: Galvanized Steel

HARDWARE FITTINGS



SOCKET EYE FOR ARCING HORN

AMERICAN STANDARD (ANSI)

Part Number	Drawing Number	Ball Type	Min. Breaking Strength (kN)	A (mm)	B (mm)	C (mm)
834490-000	A4DD07985T	Socket 52-8 & 52-11 (Type K) - R Clip	227	53	83	Ø22

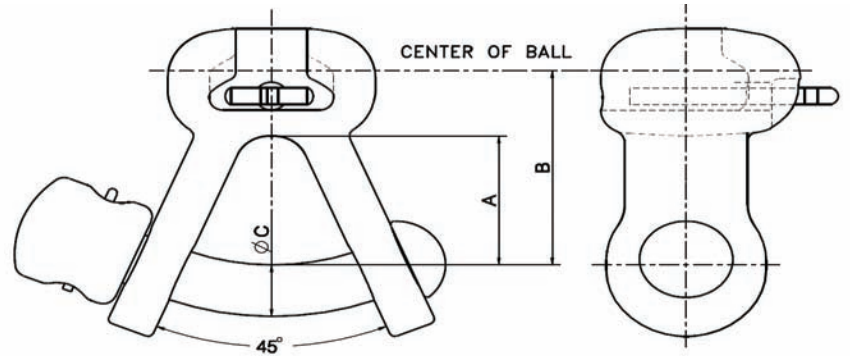
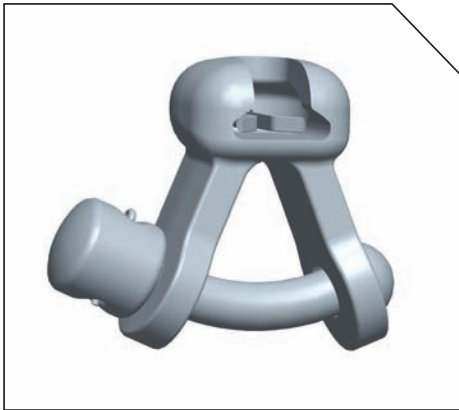

Material: Galvanized Forged Steel

SOCKET TONGUE

AMERICAN STANDARD (ANSI)

Part Number	Drawing Number	Ball Type	Min. Breaking Strength (kN)	A (mm)	B (mm)	C (mm)
617760-000	A4DD3789T	Socket 52-3 (Type B) - A Clip	120	16	64	Ø18

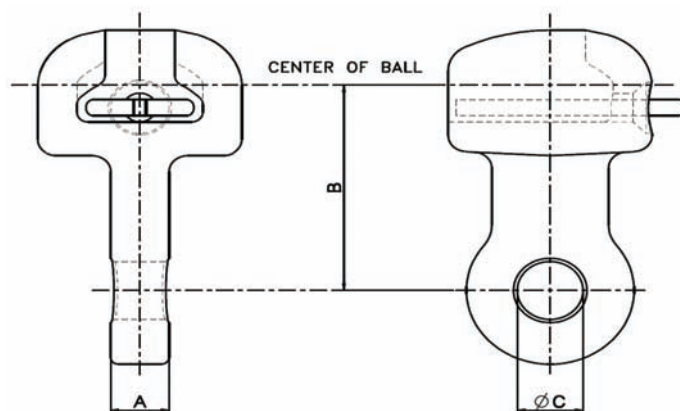

Material: Galvanized Forged Steel

HARDWARE FITTINGS



SOCKET TONGUE (CONT.)

AUSTRALIAN STANDARD (AS)

Part Number	Drawing Number	Ref Code	Min. Breaking Strength (kN)	A (mm)	B (mm)	C (mm)	E (mm)	F Ball (mm)
626400-000	ST70	PLP-ST70	70	14.5-17.5	54.2-59.8	26.5-29.5	Ø18	16
A23811-000	ST120	PLP-ST120	120	14.5-17.5	54.2-59.8	26.5-29.5	Ø18	16

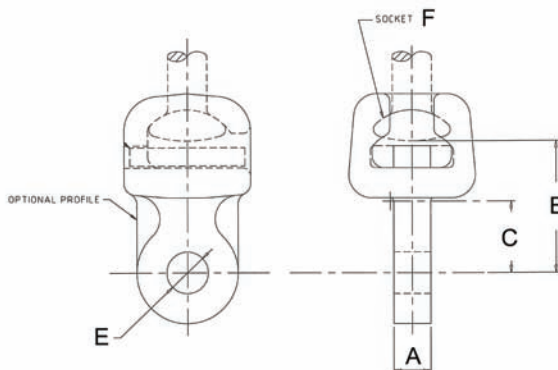

Material: Galvanized Forged Steel

SOCKET TONGUE FOR ARCING HORN

BRITISH STANDARD (BS)

Part Number	Drawing Number	Ref Code	Min. Breaking Strength (kN)	A (mm)	B (mm)	C (mm)	E (mm)	F Ball (mm)
D33006-000	DK95142/02	28/36B	125	143	70	32	20	Ø27
CL3535-000	DK95144	28/135	125	143	70	17.5	20	Ø22
701608-000	DK95242	42/36	190	159	76	38	24	Ø29

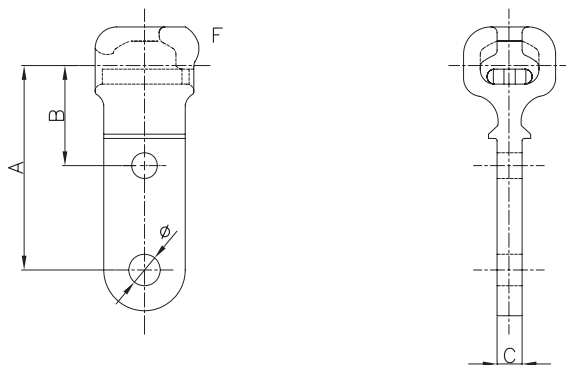
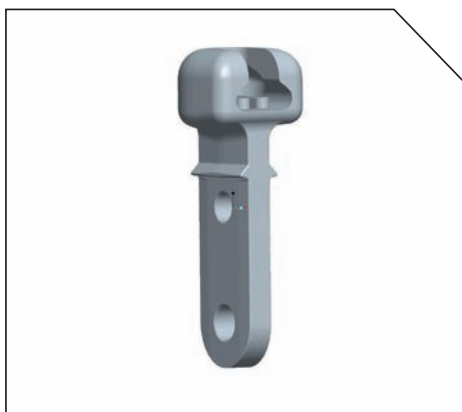

Material: Galvanized Steel

HARDWARE FITTINGS

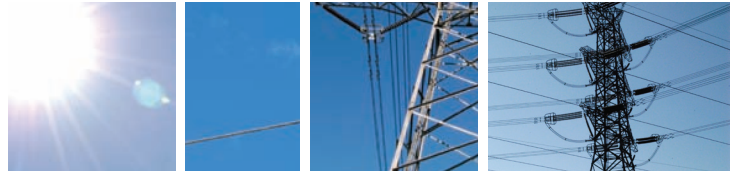

TWISTED SOCKET TONGUE

AUSTRALIAN STANDARD (AS)

Part Number	Drawing Number	Ref Code	Min. Breaking Strength (kN)	A (mm)	B (mm)	C (mm)	E (mm)	F Ball (mm)
971178-000	STT70	PLP-STT70	70	14.5-17.5	54.1-59.9	26.5-29.5	Ø18	16
CB4514-000	STT70R	PLP-STT70R	70	14.5-17.5	54.1-59.9	26.5-29.5	Ø18	16
105612-000	STT120	PLP-STT120	120	14.5-17.5	54.1-59.9	26.5-29.5	Ø18	16
447096-000	STT120R	PLP-STT120R	120	14.5-17.5	54.1-59.9	26.5-29.5	Ø18	16
267802-000	STT160	PLP-STT160	160	18.5-21.5	54.1-59.9	33.2-36.8	Ø21.5-22.5	20
598512-000	STT160R	PLP-STT160R	160	18.5-21.5	54.1-59.9	33.2-36.8	Ø21.5-22.5	20

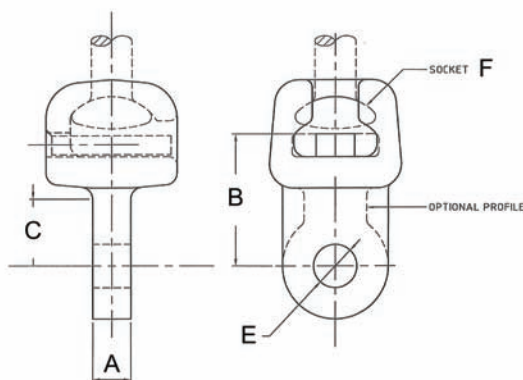

Material: Galvanized Forged Steel

TWISTED Y CLEVIS TONGUE

Part Number	Drawing Number	Min. Breaking Strength (kN)	A (mm)	B (mm)	C (mm)	D (mm)	E Bolt Size (mm)
F21902-000	A4DD06380T	120	40	84	16	Ø18	Ø16

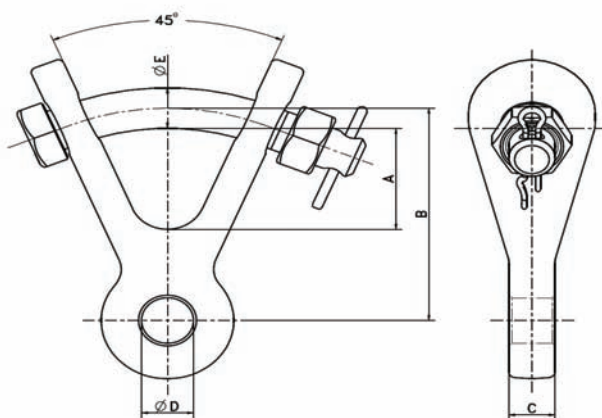

Material: Galvanized Forged Steel